



Weber County I/M Bulletin

477 23rd Street

Ogden UT, 84401

September 15, 2008

To: Weber County I/M certified test/test and repair technicians, managers, and owners. Post a copy of this technical bulletin by your analyzer for easy reference and ensure all certified technicians, managers, and owners read and sign it.

CHANGES TO NEW TESTER CERTIFICATION

With the support of the I/M Advisory Committee, the I/M Program has implemented several changes to the new tester certification requirements. A passing pretest with a score of 80% will now be required before the Self Study Manual may be purchased. Also available is an optional training class put on by the I/M Program.

Pretest The pretest will be roughly 40 questions and will focus on general automotive and emission knowledge. The test may be taken twice in a one year time period. Anyone who would like to take the free pretest may come into the Weber County Emission Center between 8:15-4:00, Monday through Friday.

Training Class An optional class will now be put on by the Weber County I/M Program on the first Wednesday of each month at 8:30. The class will cover all the material that is on the pretest and it will also help the tester prepare for the written and hands-on portion of the certification test. The cost of the class will be \$25 and will last for about three hours.

After the pretest has been passed the tester will be required to purchase a Technician Training Manual for \$45; included in that fee will be the written and practical exams. After passing both exams, a permit may be purchased for \$25 and will be valid for one year.

KIT CARS

“11.7.1 Vehicles which qualify for testing under this section shall not be eligible for a Waiver, **shall only be tested by the I/M Department**, and shall have a catalytic converter installed as required by the original chassis or engine configuration.”

Next time a Kit Car comes to your station perform the safety inspection and send them to the Vehicle Emissions Center for the I/M test.

TECH TIP # VE0045

WARNING!!!

Recently, we have become aware of a number of 2002–2008 Subaru Imprezas WRX and STI models that have been modified with illegal aftermarket down pipes from the turbo. These down pipes are illegal because they replace the pre-catalytic converter system. Any vehicles equipped with this device should be marked “FAILED” during the emissions tampering inspection. Be aware of these illegal down pipes and fail them accordingly.

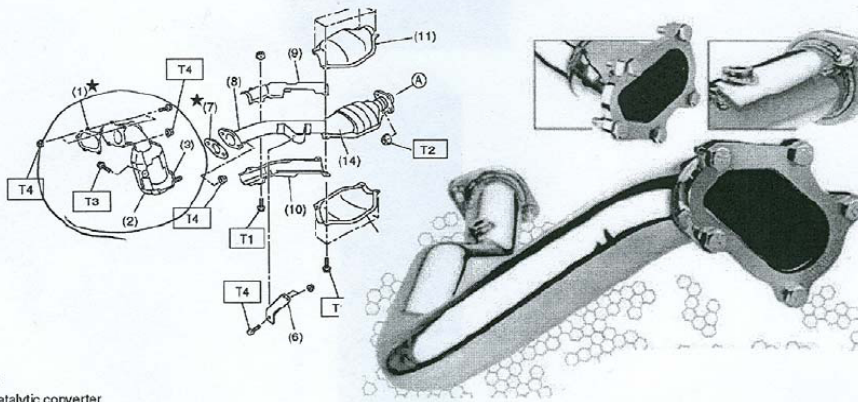

SIGNATURES

At the request of the I/M Advisory Committee, please have each owner, manager, and certified tester/technician sign this bulletin after they read it. This will help us to hold individuals responsible for their actions. Auditors will be checking this from now on as part of their routine audits.

Print

Sign
